



RDS514

MOBILE TRACK-MOUNTED FINISHING SCREEN

Feed hopper 10.5 yd³ / 8,0 m³

Screen surface 14'3" x 5' / 4,35 x 1,50 m

Transport weight ~ 58,400 lbs / 26,5 t

EFFICIENT
SCREENING
TECHNOLOGY





MOBILE TRACK-MOUNTED FINISHING SCREEN

RDS514

2-DECK

**POWERFUL
EFFICIENT
SEPARATION**



3 precisely defined fractions

POWERFUL SCREENING FOR VERSATILE MATERIAL PROCESSING

The track-mounted 2-deck screening plant RDS514 combines efficiency with robust but compact design, short setup times, superior screening results and reduced fuel consumption.

An economically preparation of almost any material such

as sand, gravel, construction and demolition waste, coal and top soil is guaranteed by the RDS514.

Like all Rockster screening plants, the RDS514 is easy to handle and can be single operated.

FEATURES & BENEFITS

- Short set-up time
- Easy handling
- Low feeding height
- Robust steel construction
- Optimal transport dimensions
- High energy screenbox
- Hydraulic folding discharge belts
- Screenbox walkways

Applications

- Produces 3 final fractions as an individual machine
- Final screening unit after the crusher to separate the crushed product in 3 final fractions

PERFORMANCE	
Max. feed size:	5" / 125 mm
Capacity:	up to 390 st/h / 350 t/h

HOPPER	
Width:	6' / 1,83 m
Length:	14'1" / 4,30
Max. Volume:	10.4 yd ³ / 8,0 m ³

TIPPING GRID	
Width:	7' / 2,17 m
Length:	16'2" / 4,95
Tip function:	Radio remote or manual

SCREEN SURFACE	
Top deck:	14' x 5' / 4,30 x 1,52 m
Bottom deck:	12' x 5' / 3,60 x 1,52 m
Angle:	22-34°

FEEDER BELT	
Width:	42" / 1050 mm
Type:	Plain belt
Control:	Variable speed

MAIN BELT	
Width:	42" / 1050 mm
Control:	Variable speed

FINES (TAIL) BELT	
Width:	48" / 1200 mm
Discharge Height:	~ 14'2" / 4,30 m
Control:	Variable speed

MIDS BELT	
Width:	26" / 650 mm
Discharge Height:	~ 14'4" / 4,40 m
Control:	Variable speed

OVERSIZE BELT	
Width:	26" / 650 mm
Discharge Height:	~ 14'4" / 4,40 m
Control:	Variable speed

AUXILIARY BELT	
Width:	20" / 500 mm
Discharge Height:	~ 15'9" / 4,80 m
Control:	Variable speed

TRACKS	
Width:	16" / 400 mm
Speed:	0,6 miles/h - 1 km/h

DRIVE UNIT	
Tier 3A	CAT 4.4 - 102HP / 75kW JCB444 DieselMax - 116HP / 85kW
Tier 4 Final	JCB444 EcoMAX - 126HP / 93kW
Diesel Tank:	122 US gallon / 465L
Hydraulic tank:	145 US gallon / 550L

OPTIONS

- > Two-deck vibrating grid
- > Screen decks: Mesh or piano wire
- > Radio remote control
- > Dust covers on main and discharge belts
- > Stage V - JCB 444 EcoMax - 126HP / 93kW



DIMENSIONS

RDS514

Working dimensions

Length:	57'4" / 17,50 m
Width:	51'2" / 15,60 m
Height:	17'3" / 5,26 m

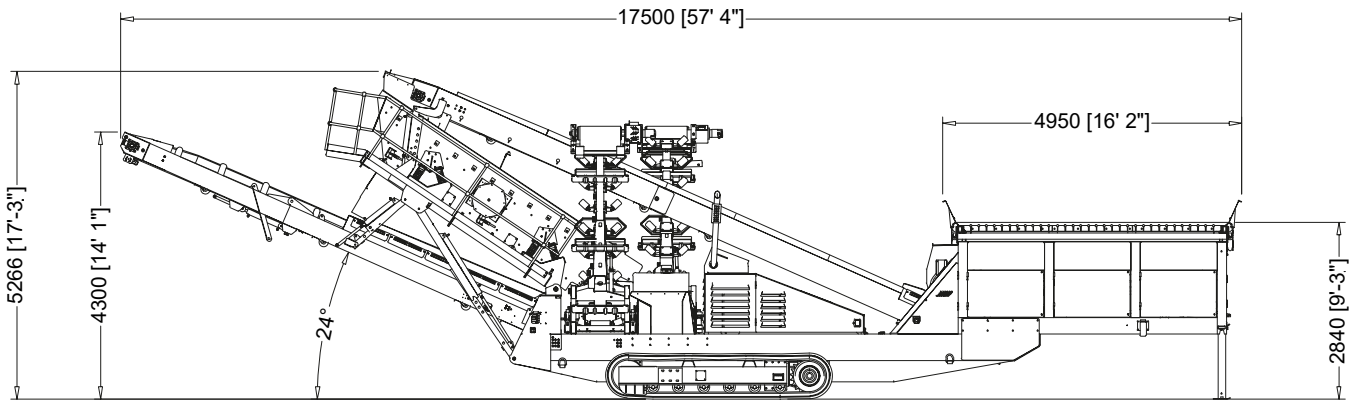
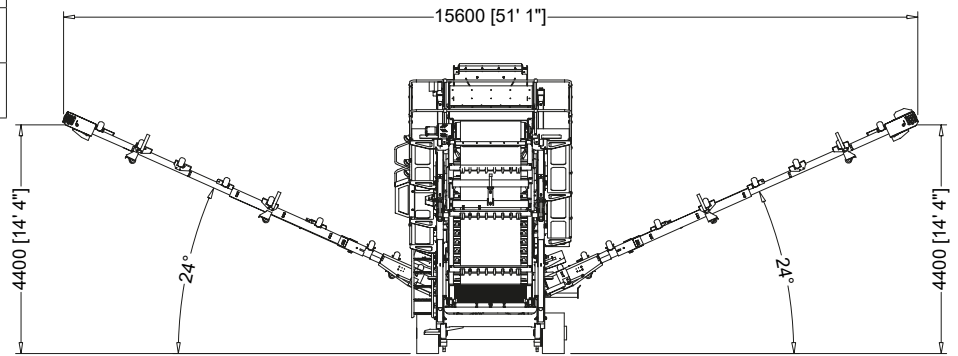

Transport dimensions

Length:	53'1" / 16,18 m
Width:	9'10" / 3,00 m
Height:	10'8" / 3,30 m

Weight:	58,400 lbs / 26,50 t
Weight with Livehead:	68,000 lbs / 31,00 t

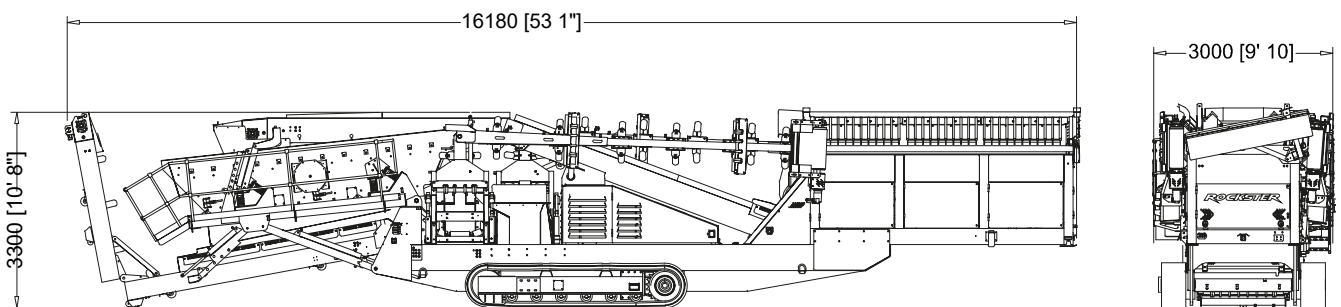

GENERAL INFORMATION



Austrian based manufacturer, Rockster Austria International GmbH has a longlasting reputation and the know-how indemolition and screening industry. The product line includes, among others, track mounted impact & jaw crushers, screening machinery, feeder conveyors and tracked stackers.

"Our mobile crushers and screeners are used for profitable & economical recycling and processing of asphalt, concrete and construction waste, as well as for natural stone. With

innovations like The Original DUPLEX system or double-functional return belt, we repeatedly demonstrate our progressive approach towards improving and developing more efficient recycling & processing methods. "

Rockster machines are sold in more than 50 countries worldwide. Our sales partner network guarantees the ideal on-site package of product and service in order to support and secure the daily success of our customers.

The Rockster concept

RELIABILITY - maximum reliability due to the highest product quality standards.

OPERATING EFFICIENCY - higher operational efficiency due to optimized transport dimensions (easy transport – no special permits needed in many cases), simple maintenance and handling.

CAPACITY - higher production capacity as a result of special high-speed rotor and enormous power reserves for the drive systems.

KNOWLEDGE - many years of practical experience in advanced machine design creates tremendous value for customers.

SERVICE - round-the-clock service and support is the company hallmark, with rapid response and immediate availability of spare and wear parts.

TECHNOLOGY - using industry-standard brand components assures adherence to the highest technical standard.

ENVIRONMENTALLY FRIENDLY - engineered to meet the highest environmental standards with the installation of low-pollution engines and complex sound suppression systems.

REVENUE - designed to meet customers' revenue and return-on-investment requirements due to low investment and operating costs. Additionally the unique advantages of the DUPLEX system maximize machine utilization with multiple crusher capabilities on one carrier.





We reserve the right to change without prior notice the information provided in this product description.

EFFICIENT SCREENING TECHNOLOGY

Rockster Austria International GmbH | Matzelsdorf 72, 4212 Neumarkt i.M., Austria
Tel.: +43 720 70 1212 | office@rockster.at | www.rockster.at

