



R900

MOBILE TRACK-MOUNTED IMPACT CRUSHER

Performance up to 270 st/h / 240 t/h*

Transport weight 56,300 lbs / 25,5 t

Fully hydraulic 

PRODUCT DESCRIPTION

EFFICIENT
CRUSHING
TECHNOLOGY



Rockster Austria International GmbH | Matzelsdorf 72, 4212 Neumarkt i.M., Austria
Tel.: +43 720 70 1212 | office@rockster.at | www.rockster.at



ROCKSTER®

* depending on material



MOBILE TRACK-MOUNTED IMPACT CRUSHER

R900

**COMPACT
FLEXIBLE
PERFORMANCE**



Perfect cubic final grain

COMPACT. FLEXIBLE. POWERFUL.

Rising landfill costs and raw material prices, as well as the need for waste separation, makes the recycling of construction materials very pertinent. This not only protects the environment, but also helps building contractors to save costs.

Rockster mobile crushers guarantee profitable recycling of

asphalt, concrete and demolition debris as well as processing of natural stone. The compact mobile track-mounted impact crusher R900 offers best mobility and high ease of use because of numerous technological refinements. Versatile setting options ensure excellent final grain quality and increased usability.

R900 IS THE MOST COMPACT SOLUTION FOR RECYCLING AND CRUSHING OF:

CONCRETE



Recycled concrete blocks 0/16

DEMOLITION DEBRIS



Subbase road 0/32

ASPHALT



Road 0/32

BRICK



Refilling pipelines 0/64

VIRGIN STONE



Forest road 0/32

MAIN DIMENSIONS

R900

Transport dimensions

Length:	31'6" / 9,60 m
Width:	8'3" / 2,50 m
Height:	10'6" / 3,20 m
Transport weight:	56.300 lbs / 25,5 t

Feeding & discharge height

Feeding height:	10'6" / 3,20 m
Main discharge belt:	~ 10'6" / 3,20 m
Side discharge belt:	~ 7'7" / 2,30 m

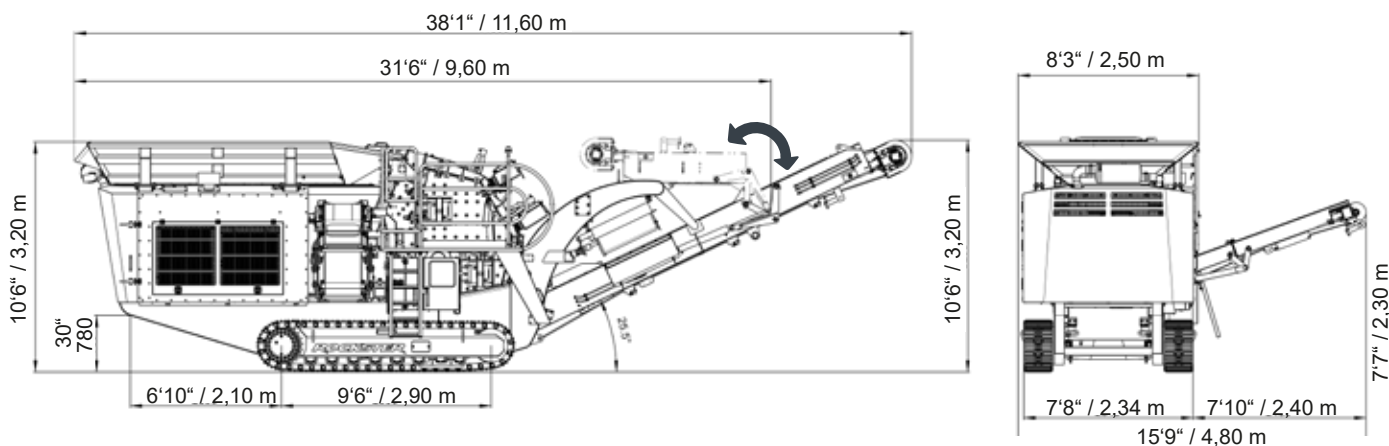

TECHNICAL DETAILS

MAXIMUM FLEXIBILITY

The Rockster impact crusher guarantees highest performance at a very high crushing ratio.

Due to two hydraulically adjustable swing-beams, as well as the rotor speed variation, the final grain can be optimally defined. High quality blow bars can be used bilaterally too and are

chosen individually depending on the application. The blow bar exchange is possible through a built-on blow bar exchange device, therefore an external lifting device is not necessary. High quality wear materials ensure reduced wear.

Impact crusher

Inlet opening:	36" x 29" / 900 x 720 mm
Impact circle diameter:	41" / 1020 mm
Rotor equipment:	4 hammers
Crushing ration:	1:10 - 1:50
Performance:	up to 270 st/h / 240 t/h
Rotor speed (continuously adjustable):	up to 850 rpm
Weight:	16,645 lbs / 7.550 kg
Drive:	hydrostatic
Gap adjustment (adjusted on display):	fully hydraulic
Dust suppression:	At the crusher inlet & outlet



Drive

Engine (electronically regulated):	Volvo Tier 3a - 200 kW / ~268 HP
	Volvo Tier 4 Final - 210 kW / ~282 HP
	Volvo STAGE V - 210 kW / ~282 HP
Cylinder:	6
Cooling system:	water

The drive system is located at the rear of the machine, enclosed in a sound-proofed housing. Engine openings are positioned on all sides for easy access, service and overall maintenance.

The hydraulic pump for all auxiliary drives (main discharge belt, side discharge belt, vibration chute, crawler gear...) as well as the pump for the hydrostat are driven via a distributing gear unit which is flange-mounted on the drive engine. The hydrostat activates the crusher via a V-belt drive.



ADVANTAGES OF THE HYDROSTATIC DRIVE

- > Elimination of conventional clutch. No wear.
- > Individual adjustment of crusher speed
- > Crusher overload protection
- > Power adjustment according to individual requirements
- > Uniform throughput
- > Enormous power reserves
- > Adjustment of rotating direction (Duplex)

Feed hopper

Material:	Hardox 400
Volume:	5.3 yd ³ / 4,0 m ³
Length:	12'6" / 3800 mm
Width:	8'2" / 2500 mm
Height:	10'6" / 3200 mm



Vibration chute with pre-screening

Material:	Hardox 450
Length:	47" / 1200 mm
Width:	36" / 900 mm
Type:	Zig zag
Option:	bar screen
Drive:	hydraulic - continuously adjustable



Bypass

The switchable chute (Bypass) enables the discharge of pre-screened material on the side or onto the main discharge belt.

Easy switch via hand lever.

No special assembly necessary.

No wear. No service.



Main discharge belt

Belt width:	40" / 1000 mm
Discharge height:	~ 10'6" / 3,20 m
Angle:	26°
Drive:	hydraulic, continuously variable

The main discharge belt is hydraulically foldable for transport purposes.



Side discharge belt

Belt width:	20" / 500 mm
Discharge height:	~ 7'6" / 2,30 m
Angle:	20°
Drive:	hydraulic

The side discharge belt is hydraulically foldable for transport purposes.



Magnetic separator

Type:	Permanent magnet
Belt width:	30" / 750 mm
Weight:	2645 lbs / 1200 kg
Drive:	hydraulic



Caterpillar crawler

Tread width:	16" / 400 mm - slanted
Wheel base:	9'6" / 2900 mm
Surface:	triple ribbed pads
Drive:	2-speed hydraulic



Control panel

Central control/operating unit ensures an easy operation and machine monitoring in connection with a wireless remote control.

Fully automatic engine Start-Stop system with only one button.

- > Save the operation settings for various applications
- > Error monitoring - error log
- > Input & output status
- > Fast start of operation (QUICKSTART-Function)



FEATURES

R900

Environmentally friendly

Reduction of emissions through:

- > efficient dust suppression
- > sound-proofed housing
- > motor drive according to the latest technology standards



Easy maintenance & ideal accessibility

Large covers enable optimal accessibility when it comes to service and maintenance. Furthermore they ensure optimal ventilation of the drive-unit and the cooler.



OPTIONS



Water pump



Blow-bar exchange system



Main belt - wear protection



Air compressor



Sound protection cover



Belt scale incl. printer

OPTIONEN

R900

DUPLEX SYSTEM

The unique design of the ROCKSTER crusher allows the transformation from a jaw crusher to an impact crusher and vice versa in only a few hours. Achieve maximum machine utilization by using one carrier and different crusher units to rapidly adapt to different job requirements.



R900
Impact crusher

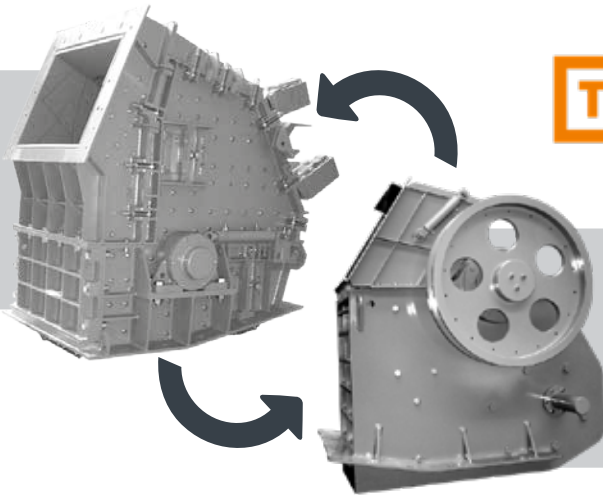

THE ORIGINAL
since 2004

R800
Jaw crusher

AIR BLOWER - for cleaner and higher quality final product

RVB1700

The Rockster Air blower RVB1700 is used to efficiently separate non-aggregates from the final end-material, which results in a cleaner and higher quality final product. This enables Rockster customers to work more environmentally friendly and economically.



Technical details

Air volume:	up to 1.700 m ³ /h / 2,223 yd ³ /h
Differential pressure:	up to 7.000 Pa
Drive power:	up to approx. 15 kW / 20 hp
Drive - rpm:	up to 3.200 min ⁻¹
Weight:	approx. 150 kg / 330 lbs



VIDEO



OPTION: SCREENING SYSTEM SCREEN BOX RS83 + RETURN BELT RB75

R900

Defined final product in one workflow

The optional screening system consists of the compact circular vibrating screen RS83 in combination with the return belt RB75. The screening system is a perfect addition for the production of 100 % defined final grain.

The components are mounted directly onto the main discharge belt and are driven through the additional hydraulic system of the crusher.



Vibrating screen

Screen size:	6' x 4' / 1830 x 1200 mm
Standard mesh:	1 1/2" / 38 mm

Special screens available on demand



Discharge conveyor - fines

Belt width:	32" / 800 mm
Discharge height:	~ 10'5" / 3,20 m



Discharge conveyor - oversize grain

Belt width:	20" / 500 mm
-------------	--------------



RB75 return belt

Belt width:	16" / 400 mm
-------------	--------------

Transport dimensions R900 + RS83 + RB75

Length:	46'7" / 14,20 m	Width:	8'3" / 2,50 m
Height:	10'8" / 3,25 m	Weight:	63,100 lbs / 28,60 t

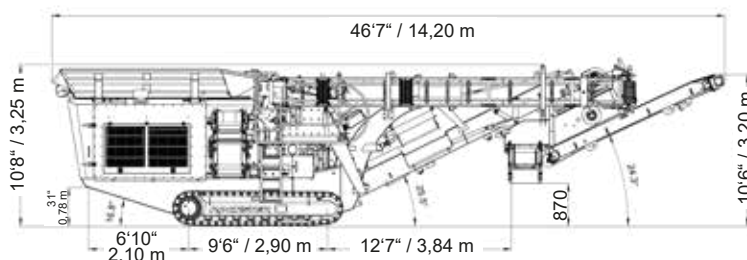

WORKING DIMENSIONS

R900

R900

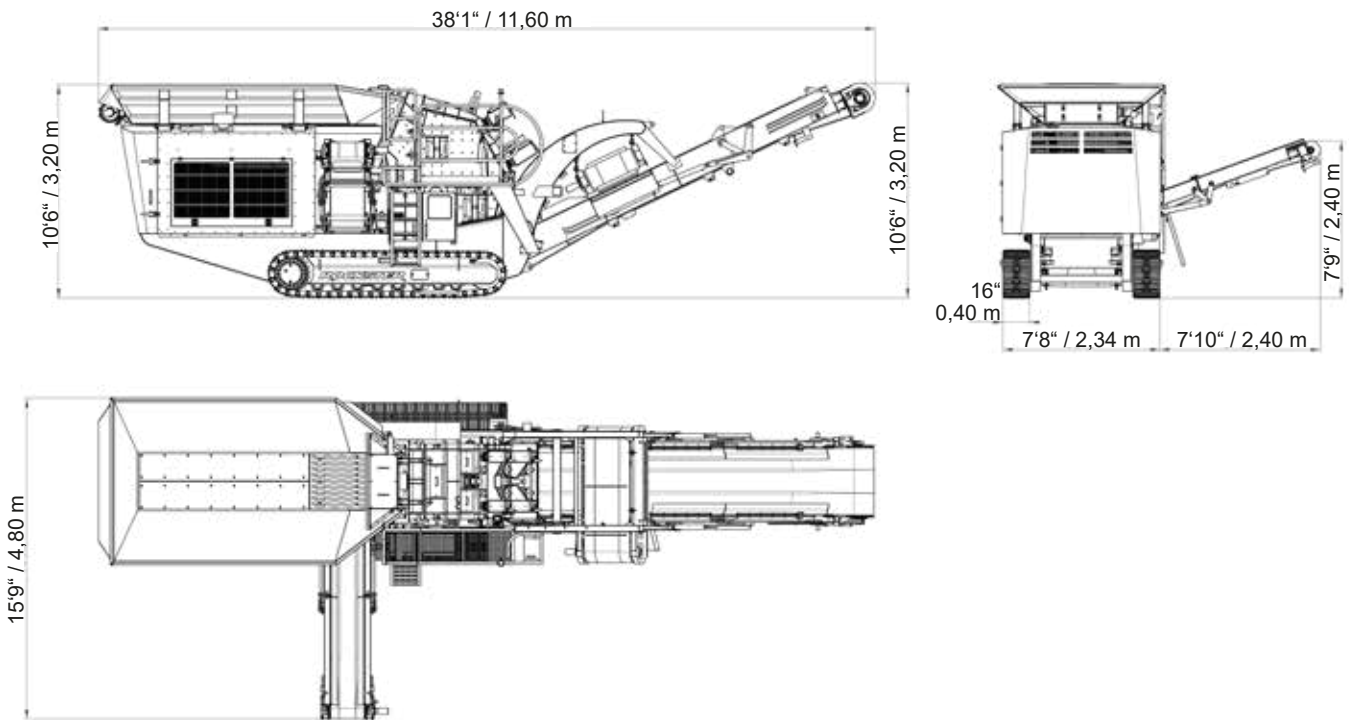

R900 with screening system

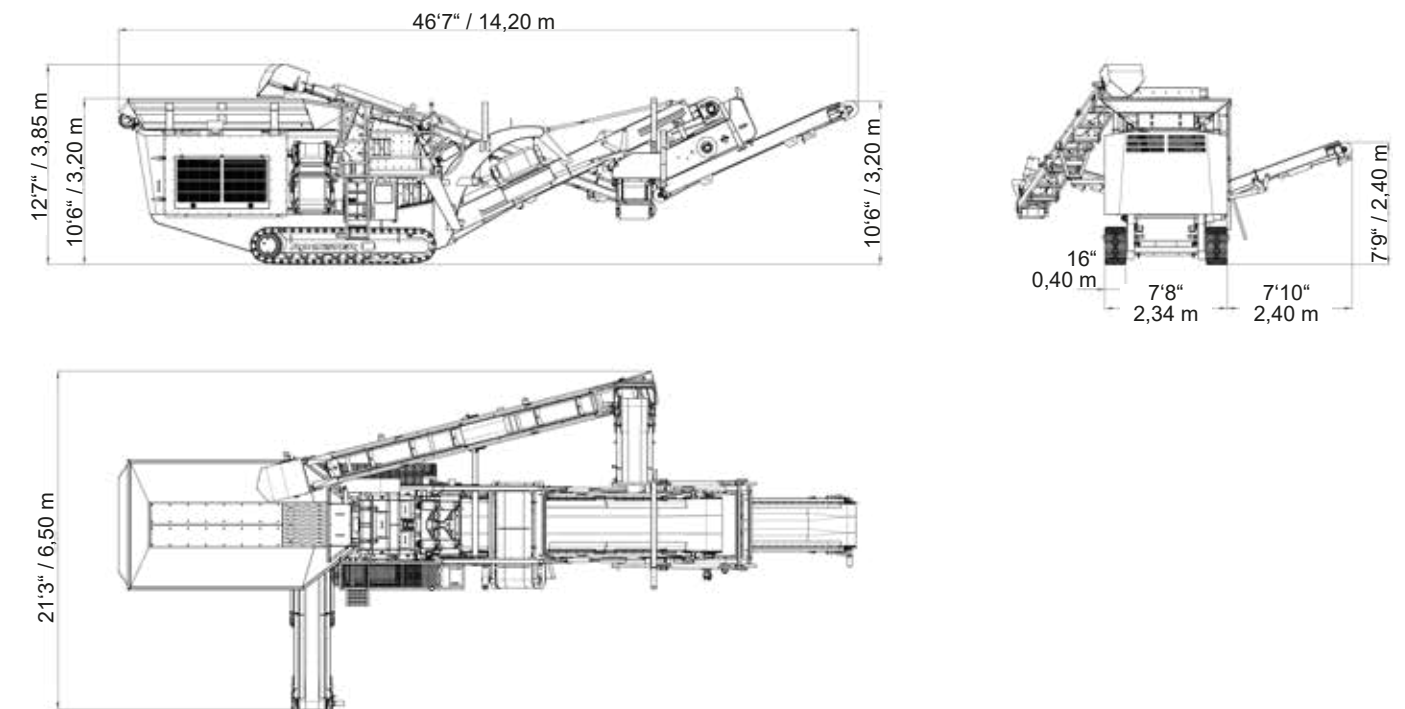

GENERAL INFORMATION



Austrian based manufacturer Rockster Austria International GmbH has a long-lasting reputation and the know-how in demolition and screening industry.

Our product line includes, among others, track mounted impact and jaw crushers, screening machinery and tracked stackers. Our mobile crushers and screeners are used for profitable & economical recycling of asphalt, concrete and construction waste, as well as for the efficient processing of natural stone.

With innovations like the first and Original DUPLEX system, double functional return belt, Rockster repeatedly demonstrates its progressive approach towards improving and developing more efficient recycling methods.

Rockster machines are sold in more than 50 countries worldwide. Because of a strong dealer network, reliable customer support and continued innovations Rockster remains one of the fastest growing companies in our industry.

The Rockster concept

RELIABILITY - maximum reliability due to the highest product quality standards.

OPERATING EFFICIENCY - higher operational efficiency due to optimized transport dimensions (easy transport – no special permits needed in many cases), simple maintenance and handling.

CAPACITY - higher production capacity as a result of special high-speed rotor and enormous power reserves for the drive systems.

KNOWLEDGE - many years of practical experience in advanced machine design creates tremendous value for customers.

SERVICE - round-the-clock service and support is the company hallmark, with rapid response and immediate availability of spare and wear parts.

TECHNOLOGY - using industry-standard brand components assures adherence to the highest technical standard.

ENVIRONMENTALLY FRIENDLY - engineered to meet the highest environmental standards with the installation of low-pollution engines and complex sound suppression systems.

REVENUE - designed to meet customers' revenue and return-on-investment requirements due to low investment and operating costs. Additionally the unique advantages of the DUPLEX system maximize machine utilization with multiple crusher capabilities on one carrier.





Note: These specifications are subject to change without notice.
Please consult your local dealer/distributor for detailed specifications.

EFFICIENT CRUSHING TECHNOLOGIE

Rockster Austria International GmbH | Matzelsdorf 72, 4212 Neumarkt i.M., Austria
Tel.: +43 720 70 1212 | office@rockster.at | www.rockster.at

