



RSS712

MOBILE TRACK-MOUNTED SCALPING SCREEN

Feed hopper 6.3 yd³ / 4,8 m³

Screen surface 12'1" x 6'7" / 3,7 x 2,0 m

Transport weight ~ 44,100 lbs / 20,0 t

**EFFICIENT
SCREENING
TECHNOLOGY**



Rockster Austria International GmbH | Matzelsdorf 72, 4212 Neumarkt i.M., Austria
Tel.: +43 720 70 1212 | office@rockster.at | www.rockster.at



ROCKSTER®



HEAVY DUTY SCALPING SCREEN

RSS712

**ROBUST
RELIABLE
FOR TOUGHEST APPLICATIONS**



DESIGNED FOR THE MOST DIFFICULT APPLICATIONS

The RSS712 scalping screen is one of the most robust and reliable scalping screens on the market. Built to handle the toughest of applications, the RSS712 comes with a double deck vibrating screen and the longest stockpiling conveyor available.

FEATURES & BENEFITS

- > Robust chassis & Track
- > Maximum durability
- > Angle adjustable screen box
- > Tipping function activated hydraulically
- > Short set-up time & easy handling
- > Low feeding height
- > Optimal transport dimensions

Technical details

HOPPER	
Width:	1,83 m / 6'1"
Length:	3,15 m / 10'4"
Max. Volume:	4,8 m ³ / 6.3 yd ³
Max. feed size	500 mm / 20" (capacity up to 600 t/h)
MAIN BELT	
Width:	1050 mm / 42"
Type:	Plain belt
Control:	variable speed
Vibrating screen (both decks):	3,70 x 2m / 12'2" x 6'9"
Drive unit:	Diesel engine

FEEDER BELT	
Width:	1050 mm / 42"
Type:	Plain belt
Control:	variable speed
DISCHARGE HEIGHT	
Minimum:	2,30 m / 7'6"
Maximum:	3,90 m / 12'8"
POWERPACK	
Tier 3A	T.Deutz - 66HP / 49kW or JCB444 DieselMax - 86HP / 63kW
Tier 4 Final	JCB444 EcoMAX - 74HP / 55kW
Diesel tank:	180L / 39 gallon / 47 US gallon
Hydraulic tank:	375L / 82 gallon / 99 US gallon

Working dimensions

Length:	40'5" / 12,30 m
Width:	8'4" / 2,56 m
Height:	13'3" / 4,05 m

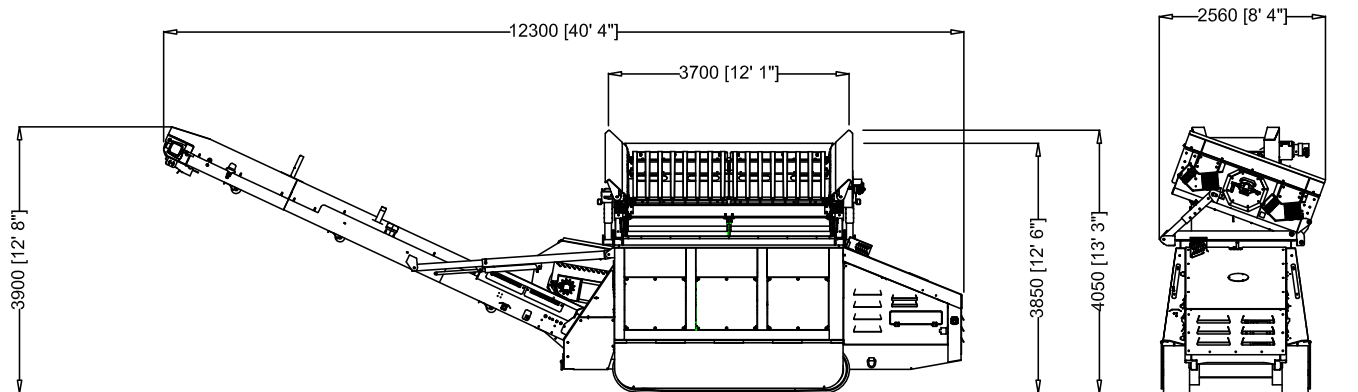

Transport dimensions

Length:	35'6" / 10,80 m
Width:	7'5" / 2,30 m
Height:	10'1" / 3,10 m
Weight:	44,000 lbs / 20,0 t

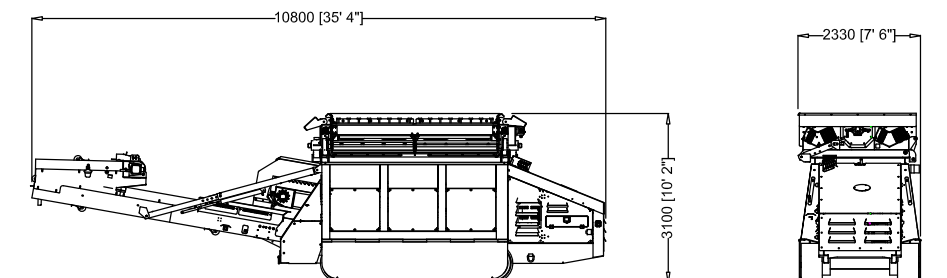

OPTIONS

- > Dust cover for the main belt
- > Radio remote control
- > Overband magnet
- > Screen decks: bofor bars, finger tines, punch plate or mech
- > Stage V engine - T.Deutz 2.9 L4 - 67HP / 50kW

GENERAL INFORMATION



Austrian based manufacturer, Rockster Austria International GmbH has a longlasting reputation and the know-how indemolition and screening industry. The product line includes, among others, track mounted impact & jaw crushers, screening machinery, feeder conveyors and tracked stackers.

"Our mobile crushers and screeners are used for profitable & economical recycling and processing of asphalt, concrete and construction waste, as well as for natural stone. With

innovations like The Original DUPLEX system or double-functional return belt, we repeatedly demonstrate our progressive approach towards improving and developing more efficient recycling & processing methods. "

Rockster machines are sold in more than 50 countries worldwide. Our sales partner network guarantees the ideal on-site package of product and service in order to support and secure the daily success of our customers.

The Rockster concept

RELIABILITY - maximum reliability due to the highest product quality standards.

OPERATING EFFICIENCY - higher operational efficiency due to optimized transport dimensions (easy transport – no special permits needed in many cases), simple maintenance and handling.

CAPACITY - higher production capacity as a result of special high-speed rotor and enormous power reserves for the drive systems.

KNOWLEDGE - many years of practical experience in advanced machine design creates tremendous value for customers.

SERVICE - round-the-clock service and support is the company hallmark, with rapid response and immediate availability of spare and wear parts.

TECHNOLOGY - using industry-standard brand components assures adherence to the highest technical standard.

ENVIRONMENTALLY FRIENDLY - engineered to meet the highest environmental standards with the installation of low-pollution engines and complex sound suppression systems.

REVENUE - designed to meet customers' revenue and return-on-investment requirements due to low investment and operating costs. Additionally the unique advantages of the DUPLEX system maximize machine utilization with multiple crusher capabilities on one carrier.





We reserve the right to change without prior notice the information provided in this product description.

EFFICIENT SCREENING TECHNOLOGY

Rockster Austria International GmbH | Matzelsdorf 72, 4212 Neumarkt i.M., Austria
Tel.: +43 720 70 1212 | office@rockster.at | www.rockster.at

