

DUPLEX **SYSTEM**

R900
IMPACT CRUSHER

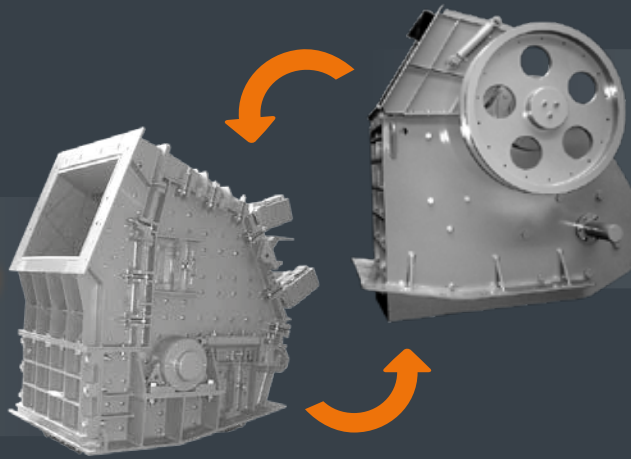

R800
JAW CRUSHER

THE ORIGINAL
since 2004

1 MACHINE
2 CRUSHERS



Rockster Austria International GmbH | Matzelsdorf 72, 4212 Neumarkt i.M., Austria
Tel.: +43 720 70 1212 | office@rockster.at | www.rockster.at



ROCKSTER[®]

PRODUCT DESCRIPTION

**DUPLEX
SYSTEM**

R800



R900



MOBILE TRACK-MOUNTED IMPACT CRUSHER

R900

MOBILE TRACK-MOUNTED JAW CRUSHER

R800

DUPLEX SYSTEM R900 / R800

**1 MACHINE
2 CRUSHERS**

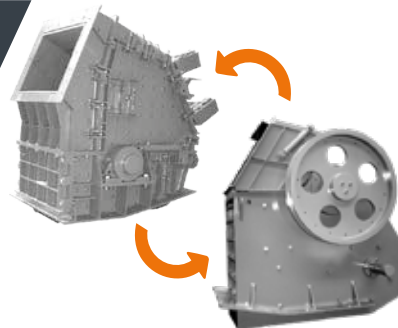

THE ORIGINAL
since 2004

FROM IMPACT TO JAW CRUSHER IN SHORTEST AMOUNT OF TIME

**DUPLEX
SYSTEM**



Change the track-mounted impact crusher (R900) to a jaw crusher (R800) and vice versa - within hours. The machine can be optimized for different requirements depending on the feeding material and because of the possibility to

have two crushing processes in one machine, it guarantees without a doubt a highly versatile and cost-effective operation.

MAIN DIMENSIONS - R900 / R800

Transport dimensions

Length:	31'6" / 9,60 m
Height:	10'8" / 3,25 m
Width:	8'3" / 2,50 m
Weight R900:	55,600 lbs / 25,50 t
Weight R800:	56,700 lbs / 25,70 t

Feeding & discharge height

Feeding height:	10'6" / 3,20 m
Main discharge belt:	~ 10'6" / 3,20 m
Side discharge belt:	~ 7'6" / 2,30 m

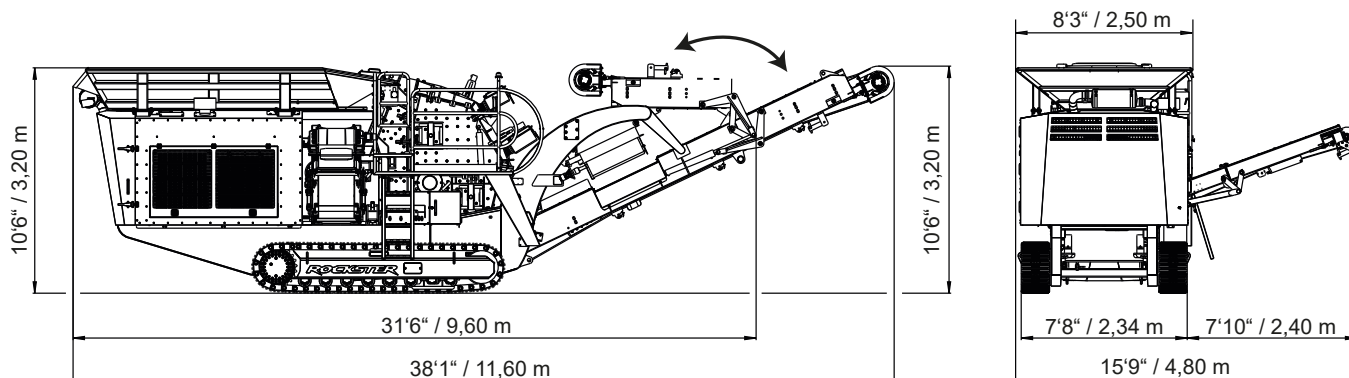



Perfect cubic final grain

ONE MACHINE - UNLIMITED POSSIBILITIES

In order to optimize the machine utilization and to guarantee a versatile operation of the crusher, the Rockster team has developed a unique Duplex System, which enables the customer to change the single crushing units. Both units can be installed onto the same chassis and the change from a jaw crusher into an impact crusher can be done in the shortest amount of time - and vice versa. With its incomparable performance, the track-mounted

impact crusher R900 yields perfect cubic final grain quality and it makes flexible operation during recycling of asphalt, concrete and rubble even easier. R800 jaw crusher is the ideal solution for any applications that demand toughest requirements when it comes to wear parts. That being said, recycling of the hardest aggregates and virgin stone is therefore done with ease.

DUPLEX-SYSTEM IS THE OPTIMAL SOLUTION FOR RECYCLING & PROCESSING

CONCRETE



Recycled concrete blocks 0/16

DEMOLITION DEBRIS



Subbase road 0/32

ASPHALT



Road 0/32

BRICK



Refilling pipelines 0/64

VIRGIN STONE



Forest road 0/32

The track-mounted mobile crushers R900/R800 are installed on the basis of a fully hydraulic principle and are mounted on the same basic chassis.

The hydrostatic drive system allows a clockwise or anti-clockwise operation of the crusher so it is possible to

install both crushing units onto the same basic frame. The machine can be changed from impact crusher to jaw crusher, and vice versa in a short amount of time.

Impact crusher

Inlet opening:	36" x 29" / 900 x 720 mm
Impact circle diameter:	41" / 1020 mm
Rotor equipment:	4 hammers
Crushing ration:	1:10 - 1:50
Performance:	up to 270 st/h / 240 t/h
Rotor speed:	up to 850 rpm
Weight:	16,645 lbs / 7.550 kg
Drive:	hydrostatic
Gap adjustment (adjusted on display):	fully hydraulic
Dust suppression:	At the crusher inlet & outlet

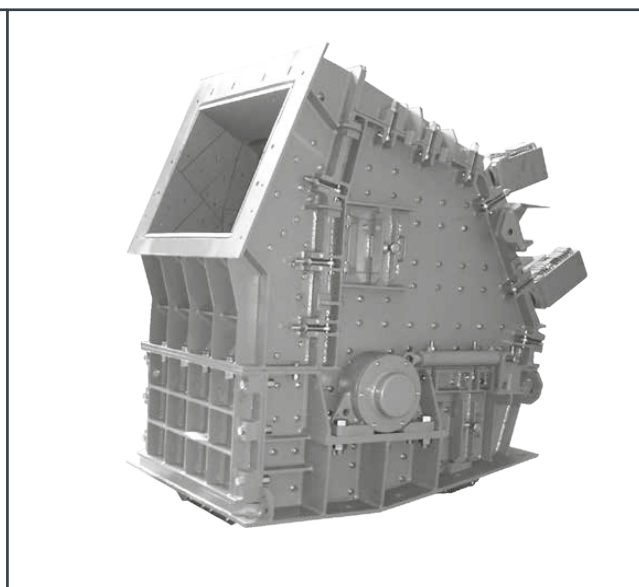

The Rockster impact crusher guarantees highest performance at a very high crushing ratio. Due to two hydraulically adjustable swing-beams, as well as a variable

rotor speed, the final grain can be fully and precisely optimized.

Jaw crusher

Inlet opening:	32" x 20" / 800 x 500 mm
Crushing ratio:	1:8
Performance:	up to 120 t/h / 140 st/h
Rotor speed (continuously adjustable):	up to 320 min ⁻¹
Weight:	17,600 lbs / 8.000 kg
Drive:	hydrostatic
Gap adjustment (adjusted on display):	fully hydraulic
Crusher outlet:	420 mm

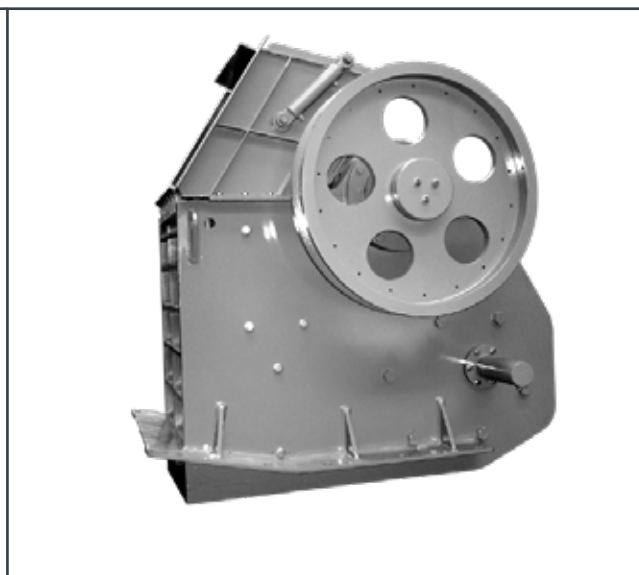

The hydraulically adjustable Rockster jaw crusher is the ideal solution for all operations that require the highest demand on wear parts.

Even under the toughest conditions, the R800 guarantees the highest crushing performance and the lowest wear.

GENERAL INFORMATION



Austrian based manufacturer Rockster Austria International GmbH has a long-lasting reputation and the know-how in demolition and screening industry.

Our product line includes, among others, track mounted impact and jaw crushers, screening machinery and tracked stackers. Our mobile crushers and screeners are used for profitable & economical recycling of asphalt, concrete and construction waste, as well as for the efficient processing of natural stone.

With innovations like the first and Original DUPLEX system, double functional return belt, Rockster repeatedly demonstrates its progressive approach towards improving and developing more efficient recycling methods.

Rockster machines are sold in more than 50 countries worldwide. Because of a strong dealer network, reliable customer support and continued innovations Rockster remains one of the fastest growing companies in our industry.

The Rockster concept

RELIABILITY - maximum reliability due to the highest product quality standards.

OPERATING EFFICIENCY - higher operational efficiency due to optimized transport dimensions (easy transport – no special permits needed in many cases), simple maintenance and handling.

CAPACITY - higher production capacity as a result of special high-speed rotor and enormous power reserves for the drive systems.

KNOWLEDGE - many years of practical experience in advanced machine design creates tremendous value for customers.

SERVICE - round-the-clock service and support is the company hallmark, with rapid response and immediate availability of spare and wear parts.

TECHNOLOGY - using industry-standard brand components assures adherence to the highest technical standard.

ENVIRONMENTALLY FRIENDLY - engineered to meet the highest environmental standards with the installation of low-pollution engines and complex sound suppression systems.

REVENUE - designed to meet customers' revenue and return-on-investment requirements due to low investment and operating costs. Additionally the unique advantages of the DUPLEX system maximize machine utilization with multiple crusher capabilities on one carrier.





Note: These specifications are subject to change without notice.
Please consult your local dealer/distributor for detailed specifications.

EFFICIENT CRUSHING TECHNOLOGIE

Rockster Austria International GmbH | Matzelsdorf 72, 4212 Neumarkt i.M., Austria
Tel.: +43 720 70 1212 | office@rockster.at | www.rockster.at

